

Edge of Arlington Saw & Tool, Inc.

124 South Collins
Arlington, TX 76010
Phone: 817-461-7171 • Fax: 817-795-6651
Toll Free: 888-461-7171
Email: info@eoasaw.com
Website: www.eoasaw.com



Item #RC-1175, Amana Tool CNC Double Edge Folding 'V' Groove for Shaping Composite Material Panels Solid Carbide Insert Knife 110°, 1 47/64" Dia x 1/2" Shank Router Bit (Industrial)

\$144.72

Thank you for shopping with us! Amana Tool CNC Double Edge Folding 'V' Groove for Shaping Composite Material Panels Solid Carbide Insert Knife 110°, 1 47/64" Dia x 1/2" Shank Router Bit (Industrial) widely used as cladding for many diverse applications such as office buildings, hospitals, convention centers, airports, hotels. Routing V-shaped grooves, whereby the aluminum cover and a part of the polyethylene core is removed, allows folding the remaining material by hand. Feed Rate (IPM) for RC-1175: 440 IPM Designed for cutting and scoring aluminum sandwich materials including:

- Aluminum, Clay, Zinc & Wood Composite Panels
- Aluminum Composite Materials (ACM)
- Aluminum Composite Panel (ACP)
- ALPOLIC® Copper Composite Material (CCM)
- Alucobond®
- Alupanel®
- Dibond®
- Durabond
- e-panel™
- Etalbond®
- Phenolics
- Plastic/Acrylic
- Plexiglas®
- Titanium Composite Material (TCM)
- Wood

MAX RPM: 18,000

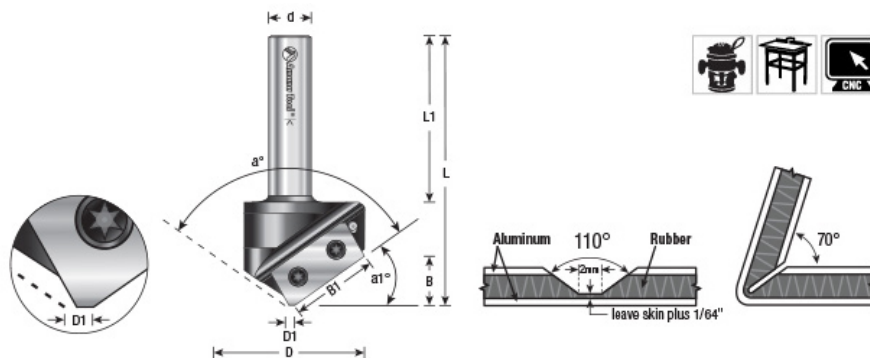

SPECIFICATIONS

Manufacturer	Amana Tool
Diameter	1 47/64 in
Cut Height, Length, or Width	37/64 in

SPECIFICATIONS

Diameter (D1)	2 mm
Flute	1
Overall Length	3 5/32 in
Shank	1/2 in
Angle	110 deg
Knives	RCK-444 - Optional GP RCK-119; MDF RCK-353