

## Edge of Arlington Saw & Tool, Inc.

124 South Collins  
Arlington, TX 76010  
Phone: 817-461-7171 • Fax: 817-795-6651  
Toll Free: 888-461-7171  
Email: [info@eoasaw.com](mailto:info@eoasaw.com)  
Website: [www.eoasaw.com](http://www.eoasaw.com)

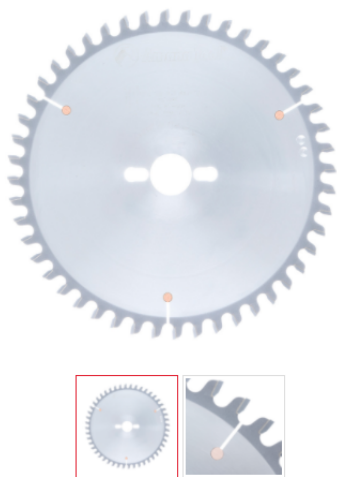

### Item #HG10480-30, Amana Tool Carbide-Tipped Hollow Ground 10" Dia x 48T HG, -6 Deg, 30mm Bore \$169.50

Thank you for shopping with us!

The specially designed saw blade makes exceptionally smooth cuts in melamine and other coated boards, without the need for scoring. The unique hollow grind, which pairs a triple-chip tooth with a raker tooth that's ground to a concave profile, produces crisp clean cuts. The grind is commonly used in vertical panel saws, such as those made by Striebig® and Holz-Her®. The negative hook angle is particularly suitable for vertical panel saws.

**Note: P.H. denotes pin-hole configuration, if applicable. Example: 2/10/60 = 2 @ 10mm dia on 60mm circle.**

**Warning:** Before use, read saw blade safety guidelines in [Amana's catalog](#).

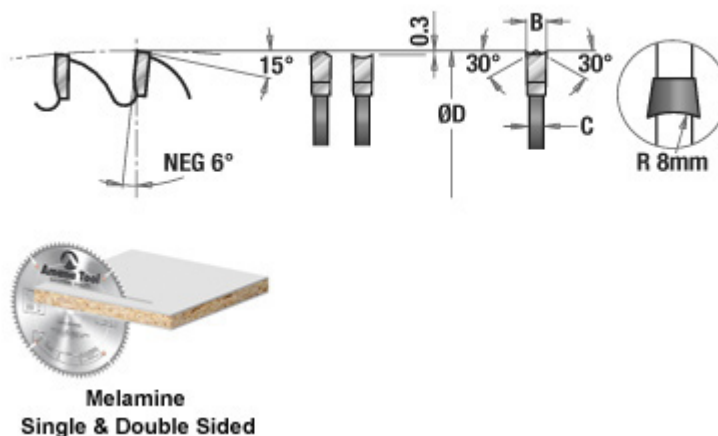

## SPECIFICATIONS

<b>Manufacturer</b>	Amana Tool
<b>Diameter</b>	10 in (253 mm)
<b>Bore</b>	30 mm
<b>Grind</b>	Hollow Ground (HG)
<b>Kerf</b>	0.126 in

## SPECIFICATIONS

<b>Machine</b>	Holz-Her
<b>Pinholes</b>	2/7/42 & 2/10/60
<b>Plate</b>	0.087 in
<b>Teeth</b>	48
<b>Hook Angle</b>	6 deg negative hook