

## Edge of Arlington Saw & Tool, Inc.

124 South Collins  
 Arlington, TX 76010  
 Phone: 817-461-7171 • Fax: 817-795-6651  
 Toll Free: 888-461-7171  
 Email: [info@eoasaw.com](mailto:info@eoasaw.com)  
 Website: [www.eoasaw.com](http://www.eoasaw.com)

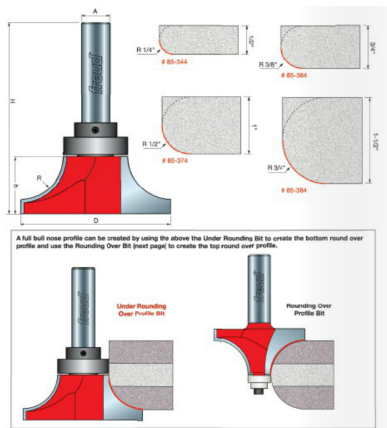

### Item #85-344, Freud Under Rounding Bit for Bull Nose \$87.64

Thank you for shopping with us! Application: Routs the lower portion of a bull nose edge -Combines these bits with the [Rounding Over Bits](#) to create perfect bull nose edges. -Specially formulated carbide is ideal for fabricating solid surface materials. -Cuts all solid surface materials. -Use in hand-held portable routers. -Includes steel bearing

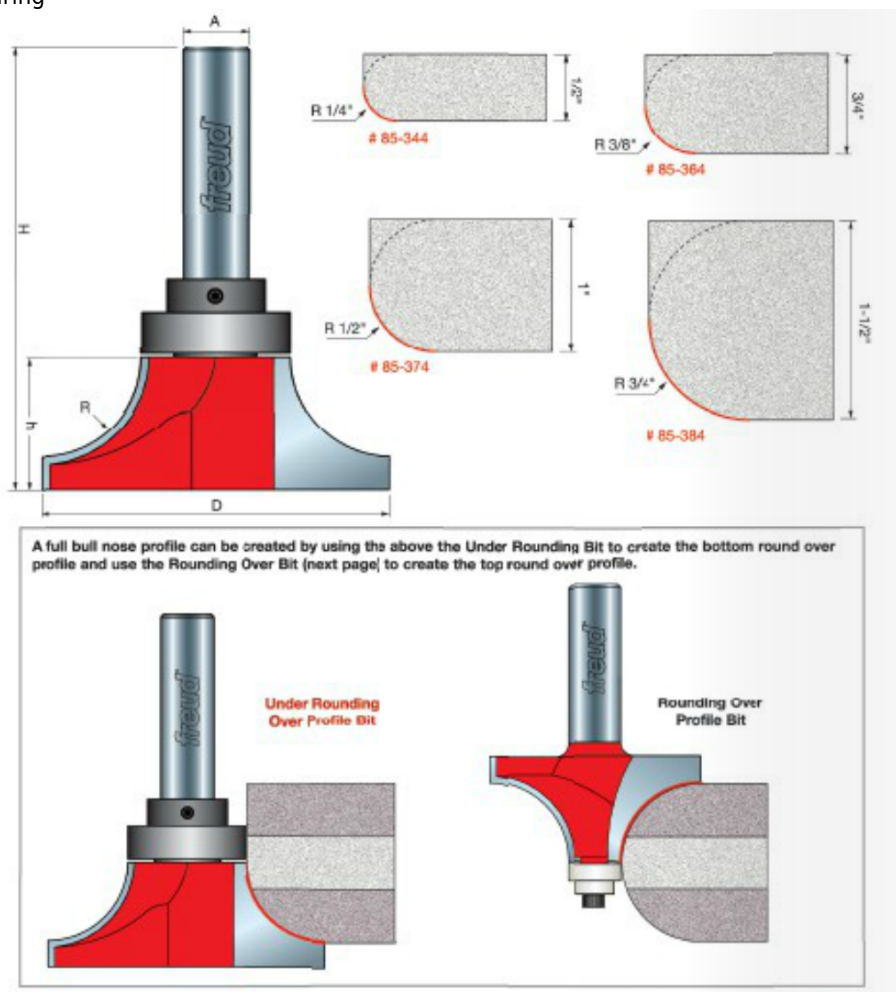

## SPECIFICATIONS

<b>Manufacturer</b>	Freud Tools
<b>Diameter</b>	1 5/8 in
<b>Cut Height, Length, or Width</b>	3/8 in
<b>Overall Length</b>	2 5/8 in

## SPECIFICATIONS

<b>Radius</b>	1/4 in
<b>Shank</b>	1/2 in
<b>Thickness</b>	Top Thickness 1/2 in