

Edge of Arlington Saw & Tool, Inc.

124 South Collins
Arlington, TX 76010
Phone: 817-461-7171 • Fax: 817-795-6651
Toll Free: 888-461-7171
Email: info@eoasaw.com
Website: www.eoasaw.com



Item #712960, Amana Tool Carbide-Tipped Heavy Duty Cut-Off & Crosscut 12 Inch Dia x 96T ATB, 10 Deg, 1 Inch Bore \$236.40

Thank you for shopping with us!

This is a heavy duty production blade for general trimming and crosscutting of hardwood and softwood. It has an extra-thick plate and cuts a wide kerf. The hook angle is aggressive, varying from 10 to 18 degrees, depending on the tooth count and blade diameter. All blades feature the alternate top bevel grind for clean cuts.

Appropriate for use on table saws and radial arm saw.

Warning: Before use, read saw blade safety guidelines in [Amana's catalog](#).

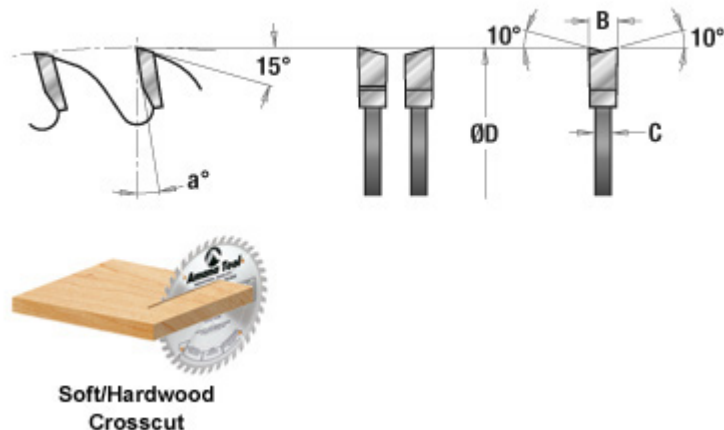

SPECIFICATIONS

| | |
|-----------------|----------------|
| Diameter | 12 in (300 mm) |
| Bore | 1 in |
| Grind | ATB |
| Kerf | 0.173 in |
| Angle | 10 deg |
| Plate | .110 in |

SPECIFICATIONS

Teeth

96

Manufacturer

Amana Tool