

Edge of Arlington Saw & Tool, Inc.

124 South Collins
Arlington, TX 76010
Phone: 817-461-7171 • Fax: 817-795-6651
Toll Free: 888-461-7171
Email: info@eoasaw.com
Website: www.eoasaw.com



Item #55212, Amana Tool Carbide-Tipped 82 Degree Countersink #12 Screw 15/32 Dia x 7/32 Drill Dia x 3/8 Round Shank \$38.66

Thank you for shopping with us! With slow spiral, HSS M2 DIN 338 fully ground drill. Used to countersink holes for the heads of screws in woods, plastic, and non-ferrous materials. The 2-flute integral design ensures uniform and concentric results every time. Carbide tips provide chip-free hole edges and last at least 40 times longer than steel countersinks. Available in a wide variety of sizes; complete with the HSS M2 fully ground drill bit. Excellent for drilling: natural woods, man-man boards, MDF, chipboard, plywood, aluminum/non-ferrous, aluminum composite material (ACM), composite decking materials. **Warning:** When drilling aluminum/non-ferrous materials, for optimal results and extended tool life use lubricant or air cooling. Make sure the material is fixed and drill is stable during drilling.

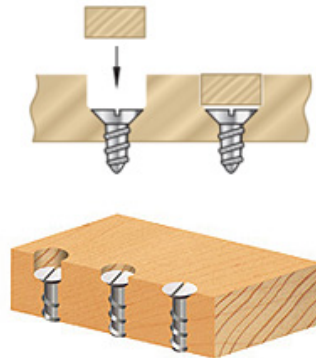
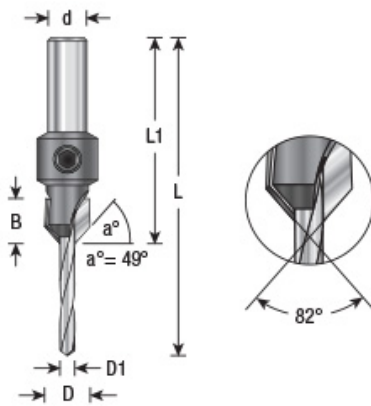

SPECIFICATIONS

Manufacturer	Amana Tool
Diameter	15/32 in
Cut Height, Length, or Width	1/2 in
Diameter (D1)	7/32 in
Replacement Parts	630-502
Flute	2
Length	1 3/4 in w/o Drill
Overall Length	3 in
Screw Size	#12
Shank	3/8 in