

Edge of Arlington Saw & Tool, Inc.

124 South Collins
Arlington, TX 76010
Phone: 817-461-7171 • Fax: 817-795-6651
Toll Free: 888-461-7171
Email: info@eoasaw.com
Website: www.eoasaw.com



Item #54234, Amana Tool Architectural Molding Carbide-Tipped #12 1 3/16" D x 1/2" Shank 2-Flute w/Ball Bearing Guide \$102.68

Thank you for shopping with us!

Amana Tool Architectural Molding Carbide-Tipped #12 1 3/16" D x 1/2" Shank 2-Flute w/Ball Bearing Guide

These bits are designed for routing architectural and furniture moldings and trim. Almost all have the profile laid out vertically, reducing the diameter of the bit. These bits should be used in a 2+ horsepower, table-mounted router, and many should be run at reduced speed. Although most have ball bearing guides, guiding the cuts with the fence is recommended.

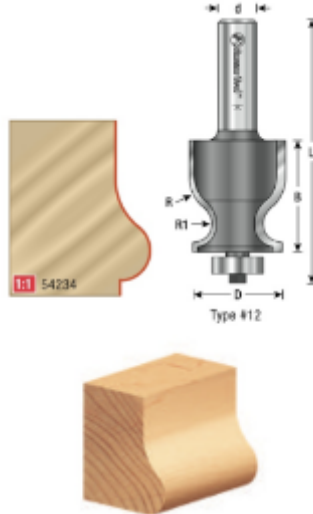

SPECIFICATIONS	
Manufacturer	Amana Tool
Diameter	1 3/16 in
Cut Height, Length, or Width	1 3/8 in
Bearing(s)	47716
Diameter (D1)	--
Flute	2 w/Bearing
Note	--

SPECIFICATIONS

Overall Length	3 1/4 in
Radius	1/2 in
R1/Radius	1/4 in
R2/Radius	N/A
R3/Radius	N/A
Shank	1/2 in
Type	#12