

Edge of Arlington Saw & Tool, Inc.

124 South Collins
Arlington, TX 76010
Phone: 817-461-7171 • Fax: 817-795-6651
Toll Free: 888-461-7171
Email: info@eoasaw.com
Website: www.eoasaw.com

Item #54173, Amana Tool Carbide-Tipped Ogee 7/32" Radius x 1-1/4" Dia x 1/2" Shank for 1-1/8" Material - Screen Door System \$46.65

Thank you for shopping with us! Want the beauty of traditional cope and stick doors with the strength and longevity of true mortise-and-tenon joinery? Our design allows you to make beautiful doors with tenons of any length you choose. This unique door-making system utilizes a "stub" spindle & cope cutter arrangement. The counterbored cope cutter is secured to the spindle with a cap screw. A matching profile bit is used to shape the decorative ogee "sticking" along the edges of the stiles and rails. As the cope is cut on the ends of the rails, the tenon passes over the top of the bit unobstructed. Each stub spindle & cope cutter includes a full color instruction manual.

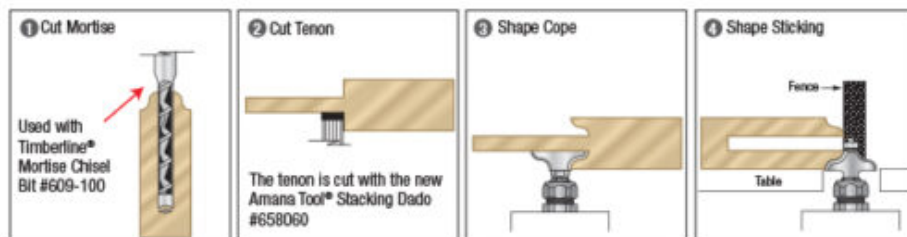
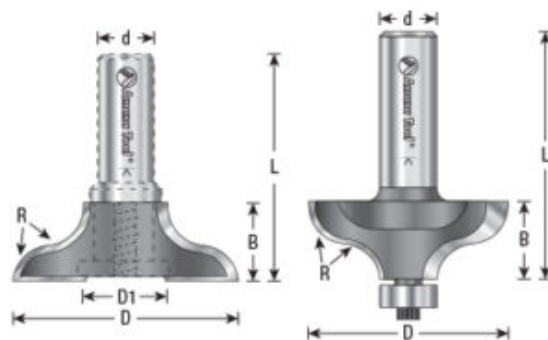
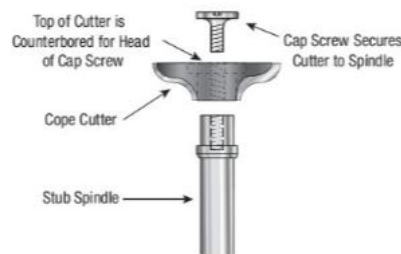

SPECIFICATIONS

Manufacturer	Amana Tool
Bearing(s)	47706
Diameter	1 1/4 in
Cut Height, Length, or Width	15/32 in
Diameter (D1)	--
Replacement Parts	Cope Cutter #47512, Stub Spindle w/screw #47617, Screw 67012
Flute	2
Material	1 1/8 in
Overall Length	1 7/16 in
Radius	7/32 in
Shank	1/2 in
Type	Ogee Bit
Usage/System	Screen Door