

Edge of Arlington Saw & Tool, Inc.

124 South Collins
Arlington, TX 76010
Phone: 817-461-7171 • Fax: 817-795-6651
Toll Free: 888-461-7171
Email: info@eoasaw.com
Website: www.eoasaw.com



Item #51437, Amana Tool Plastic Cutting CNC Spiral O Flute Mirror Finish Solid Carbide 1/8 x 3/4 x 1/8 Shank Upcut Router Bit

\$35.85

Thank you for shopping with us!

Produce super-clean smooth cuts, especially in acrylic materials (Plexiglas®, Lucite®), other plastics, and wood. Bits are made according to strict tolerances from an exclusive carbide grade and polished to a mirror finish using Amana's unique process. Ideal for industrial applications and CNC machines.

Excellent for cutting: plastic/acrylic, acrylonitrile butadiene styrene (ABS), alupanel®, acetal & nylon, corrugated polypropylene, delrin, gator board, foam board, high density polyethylene (HDPE), Lucite®, mechanical/engineered plastics, Plexiglas®, polycarbonates, solid surface, ultra high molecular weight polyethylene (UHMW), and wood.

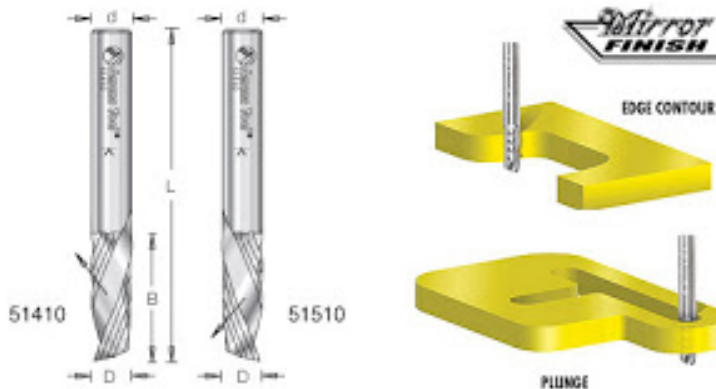

Benefits of

Mirror-Finish: Razor sharp cutting edge. Effortless chip removal. Helps prevent chip re-welding. Extends tool life. Exceptional cut quality. Dissipates heat well and prevents melting.

*Router collet reducer RB-102 (1/4 to 1/8) available for 1/8 shank bits—see below to purchase separately.

SPECIFICATIONS

Manufacturer	Amana Tool
Diameter	1/8 in
Cut Height, Length, or Width	3/4 in

SPECIFICATIONS

Flute Geometry	Upcut
Flute	1
Includes	--
Overall Length	2 in
Shank	1/8 in