

## Edge of Arlington Saw & Tool, Inc.

124 South Collins  
Arlington, TX 76010  
Phone:817-461-7171 • Fax: 817-795-6651  
Toll Free: 888-461-7171  
Email: [info@eoasaw.com](mailto:info@eoasaw.com)  
Website: [www.eoasaw.com](http://www.eoasaw.com)



### Item #514101-5/8HD, Amana Tool Carbide-Tipped Aluminum & Non-Ferrous Metals 14 Inch Dia x 100T TCG, -6 Deg, 5/8 Bore - For Thin Material \$238.24

Thank you for shopping with us!  
For Thin Material (under 0.25" )

Ideal for cutting aluminum and non-ferrous metal bars such as copper, brass, bronze, and lead. It is also good for cutting extrusions and profiles. The negative hook angle ( $-6^\circ$ ), triple-chip grind, and thick plate combine to produce a superior finish. The blade can also be used to cut other "difficult" materials such as plastic, PVC tubing, fiberglass, and ACM such as Alucobond®, Dibond®, and Durabond. Use a coolant or blade wax and clamp down the workpiece when cutting non-ferrous metals.

**Warning:** Never attempt to cut ferrous metals (steel, iron, etc.) with these saw blades!

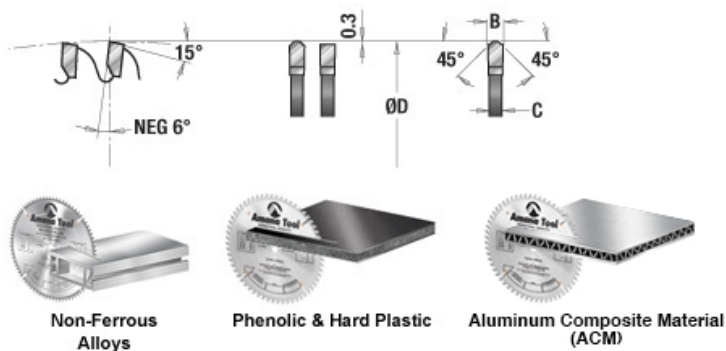

## SPECIFICATIONS

<b>Manufacturer</b>	Amana Tool
<b>Bore</b>	5/8 in
<b>Diameter</b>	14 in (350 mm)
<b>Grind</b>	TCG
<b>Hook Angle</b>	6 deg negative hook
<b>Kerf</b>	0.146

## SPECIFICATIONS

<b>Pinholes</b>	--
<b>Plate</b>	.118 in
<b>Teeth</b>	100
<b>Material</b>	For Thin Material (under 0.25 in)