

Edge of Arlington Saw & Tool, Inc.

124 South Collins
Arlington, TX 76010
Phone: 817-461-7171 • Fax: 817-795-6651
Toll Free: 888-461-7171
Email: info@eoasaw.com
Website: www.eoasaw.com



Item #49622, Amana Tool Carbide-Tipped Beading 1" Radius x 2 1/2" Dia x 1 1/4" x 1/2" Shank w/ 3/8" Dia Ball Bearing Guide **\$113.55**

Thank you for shopping with us!

Cut a quarter-round shape bound by fillets, known as a bead, in one pass. The width of one fillet is set by the pilot bearing size, while the other is controlled by the depth of cut. A beading bit can be transformed to a corner rounding bit by changing the bearing (and vice versa).

Replacement bearing 47702

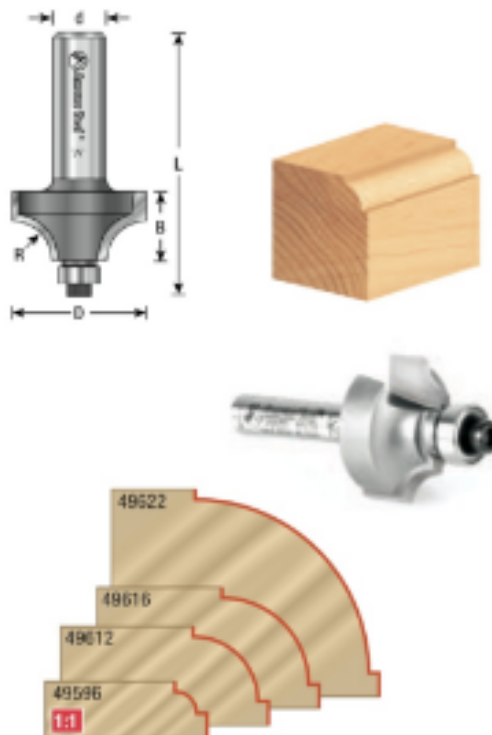

Replacement bearing 47702

Warning: Maximum RPM = 18,000. Use in a table-mounted router—not for use in a handheld router.

Not guaranteed due to extreme diameter and radius. For best results it is recommended to use a smaller radius bit or chamfer the material prior to using these large radius tools. Tool life will be prolonged and a smoother finish will result.

SPECIFICATIONS

Manufacturer	Amana Tool
Diameter	2 1/2 in
Cut Height, Length, or Width	1 1/4 in
Flute	2 w/Bearing
Bearing(s)	47702
Overall Length	3 3/16 in
Radius	1 in
RPM	--
Shank	1/2 in
Note	Use in a table-mounted router; not for use in a handheld router! Not guaranteed due to extreme diameter & radius.