

**Edge of Arlington Saw & Tool, Inc.**

124 South Collins  
 Arlington, TX 76010  
 Phone: 817-461-7171 • Fax: 817-795-6651  
 Toll Free: 888-461-7171  
 Email: [info@eoasaw.com](mailto:info@eoasaw.com)  
 Website: [www.eoasaw.com](http://www.eoasaw.com)

**Item #47513, Amana Tool Carbide-Tipped Cope Cutter with Stub Spindle - 7/32" Radius x 1-1/2" Dia x 1/2" Shank for 1-1/8" Material - Screen Door System \$55.99**



Thank you for shopping with us! Want the beauty of traditional cope and stick doors with the strength and longevity of true mortise-and-tenon joinery? Our design allows you to make beautiful doors with tenons of any length you choose. This unique door-making system utilizes a "stub" spindle & cope cutter arrangement. The counterbored cope cutter is secured to the spindle with a cap screw. A matching profile bit is used to shape the decorative ogee "sticking" along the edges of the stiles and rails. As the cope is cut on the ends of the rails, the tenon passes over the top of the bit unobstructed. Each stub spindle & cope cutter includes a full color instruction manual.

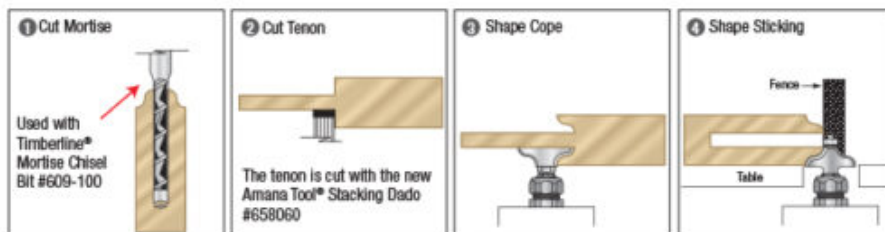
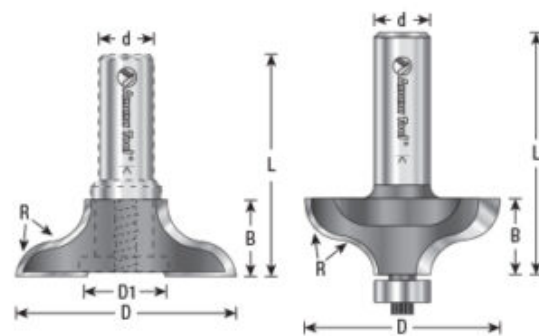
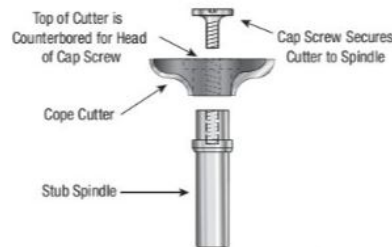

## SPECIFICATIONS

<b>Manufacturer</b>	Amana Tool
<b>Bearing(s)</b>	47706
<b>Diameter</b>	1 1/2 in
<b>Cut Height, Length, or Width</b>	15/32 in
<b>Diameter (D1)</b>	3/4 in
<b>Replacement Parts</b>	Cope Cutter #47512, Stub Spindle w/screw #47617, Screw 67012
<b>Flute</b>	2
<b>Material</b>	1 1/8 in
<b>Overall Length</b>	2 in
<b>Radius</b>	7/32 in
<b>Shank</b>	1/2 in
<b>Type</b>	Cope Cutter w/Stub Spindle
<b>Usage/System</b>	Screen Door