

Edge of Arlington Saw & Tool, Inc.

124 South Collins
Arlington, TX 76010
Phone: 817-461-7171 • Fax: 817-795-6651
Toll Free: 888-461-7171
Email: info@eoasaw.com
Website: www.eoasaw.com



Item #47210, Amana Tool Special Bevel Trim Carbide-Tipped 8° 5/8" Dia x 15/32" x 1/4" Shank 2-Flute with Ball Bearing Guide

\$30.08

Thank you for shopping with us! A very shallow bevel angle, the gap between the cutting edges, and the ball bearing pilot are the key features of this Amana Tool Special Bevel Trim Carbide-Tipped 8° 5/8" Dia x 15/32" x 1/4" Shank 2-Flute with Ball Bearing Guide. The gap collects adhesive residue that usually fouls the pilot and thus degrades the cut.

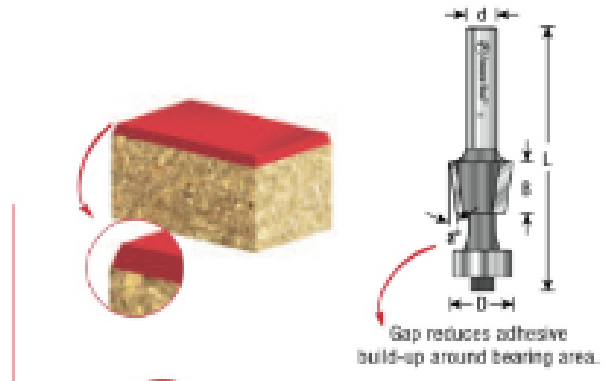

SPECIFICATIONS

Manufacturer	Amana Tool
Diameter	5/8 in
Cut Height, Length, or Width	15/32 in
Bearing(s)	Standard replacement bearing (.500 in dia) #47706 or new #47715 (.492 in dia) for use after sharpening
Flute	2 w/Bearing
Note	A special 8 deg bevel tool with a gap (.287 in) to reduce glue build-up
Overall Length	2 1/4 in
Shank	1/4 in
Angle	8 deg