

Edge of Arlington Saw & Tool, Inc.

124 South Collins
Arlington, TX 76010
Phone: 817-461-7171 • Fax: 817-795-6651
Toll Free: 888-461-7171
Email: info@eoasaw.com
Website: www.eoasaw.com



Item #45219, Amana Tool Carbide-Tipped Metric Straight Plunge for Undersized Plywood Dado 10mm x 19mm x 1/4" Shank, 2-Flute \$21.98

Thank you for shopping with us!

In choosing a straight bit for any application, always select one with the shortest cutting edges and the shortest overall length that will reach the required cut depth. Excessive length intensifies deflection and vibration, which degrades cut quality and leads to tool breakage.

Use a two-flute bit where fine finish is paramount. Two flutes balance the bit, eliminating vibration that degrades the cut finish. Two cuts per revolution yield a smooth surface, but feed rate is slightly reduced.

Many standard metric plunge bits from 3mm to 51mm are available on special order. Allow 2-3 weeks for delivery.

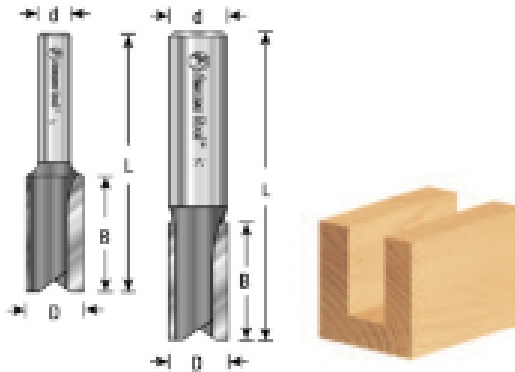

SPECIFICATIONS

Manufacturer	Amana Tool
Application	Ideal For: Undersized Plywood Dado
Diameter	10 mm
Cut Height, Length, or Width	19 mm
Flute	2
Note	--
Overall Length	2 1/8 in
Shank	1/4 in