

Edge of Arlington Saw & Tool, Inc.

124 South Collins

Arlington, TX 76010

Phone: 817-461-7171 • Fax: 817-795-6651

Toll Free: 888-461-7171

Email: info@eoasaw.com

Website: www.eoasaw.com



Amana Tool CNC Face Milling for Non-Ferrous Metals End Mill/Router Bit

Thank you for shopping with us! Amana Tool CNC Face Milling for Non-Ferrous Metals End Mill/Router Bit - Replaceable tips end mill/router bit tool body made from alloy steel with 4 solid carbide cutting inserts for maximum feed and stability, specially made for CNC and milling machines. Each of the solid carbide tips has 4 cutting rounded corners that can be "dialed;" made from micrograin carbide for maximum tool life. **Excellent for cutting:**

- Aluminum
- Bronze
- Copper

Applications:

- Milling / Surfacing / Facing
- Shouldering / Rabbeting
- Slotting / Grooving

Use "Ramp Down" technique Feed Rate: 25"/min - 63"/min Chip load per tooth: 0.0008" - 0.002" Maximum RPM: 8,000 RPM

Warning: Maximum recommended material depth in one pass 1/32" (1.0mm).

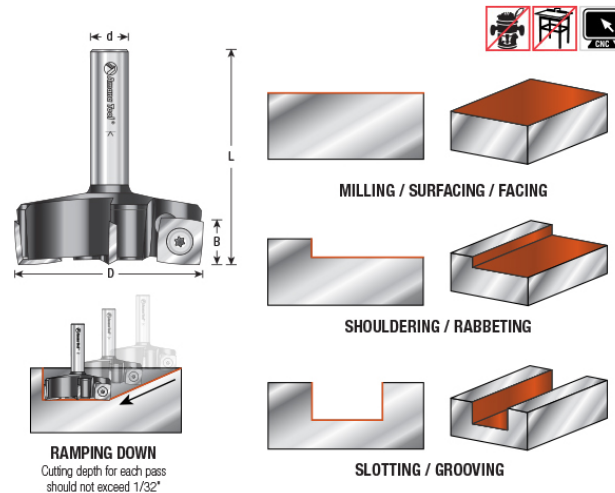

Item #	Manufacturer	Diameter	Cut Height, Length, or Width	Flute	Replacement Parts	Overall Length	RPM	Shank	Price
RC-3400	Amana Tool	2 31/64 in	15 mm	4	RCK-458	2 53/64 in	8,000 Max RPM	1/2 in	\$257.58