

**Edge of Arlington Saw & Tool, Inc.**

124 South Collins  
 Arlington, TX 76010  
 Phone:817-461-7171 • Fax: 817-795-6651  
 Toll Free: 888-461-7171  
 Email: [info@eoasaw.com](mailto:info@eoasaw.com)  
 Website: [www.eoasaw.com](http://www.eoasaw.com)



**Amana Tool Special Bevel Trim Carbide-Tipped 2-Flute with Ball Bearing Guide**

Thank you for shopping with us! A very shallow bevel angle, the gap between the cutting edges, and the ball bearing pilot are the key features of this Amana Tool Special Bevel Trim Carbide-Tipped 2-Flute with Ball Bearing Guide bit. The gap collects adhesive residue that usually fouls the pilot and

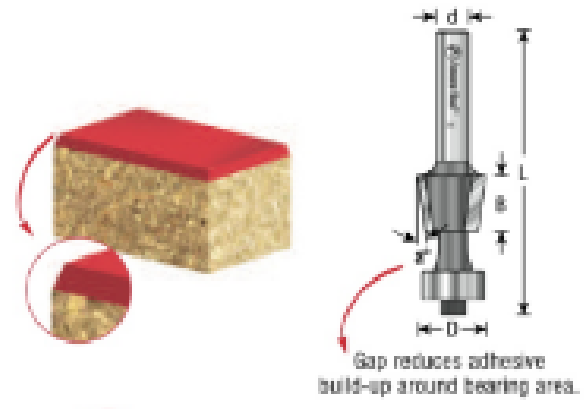

thus degrades the cut.

Item #	Manufacturer	Diameter	Cut Height, Length, or Width	Bearing(s)	Flute	Note	Overall Length	Shank	Angle	Price
47210	Amana Tool	5/8 in	15/32 in	Standard replacement bearing (.500 in dia) #47706 or new #47715 (.492 in dia) for use after resharpener	2 w/Bearing	A special 8 deg bevel tool with a gap (.287 in) to reduce glue build-up	2 1/4 in	1/4 in	8 deg	<b>\$30.08</b>