

## Edge of Arlington Saw & Tool, Inc.

124 South Collins

Arlington, TX 76010

Phone: 817-461-7171 • Fax: 817-795-6651

Toll Free: 888-461-7171

Email: [info@eoasaw.com](mailto:info@eoasaw.com)

Website: [www.eoasaw.com](http://www.eoasaw.com)

### Amana Tool 3°, 5°, and 7° Carbide-Tipped Patternmakers

Thank you for shopping with us! This slightly tapered bit is specifically designed for wood patternmaking, especially wood vacuum-forming molds where draft (3°, 5°, and 7° taper) is required for releasing the styrene or other plastic from the mold. It can be used to bevel the leading edge on a door. #47144: Not for use in CNC machines Replacement bearing for #47144 use #47706

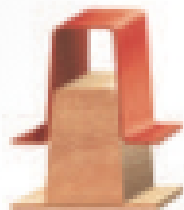

Vacuum-forming  
mold (wooden)

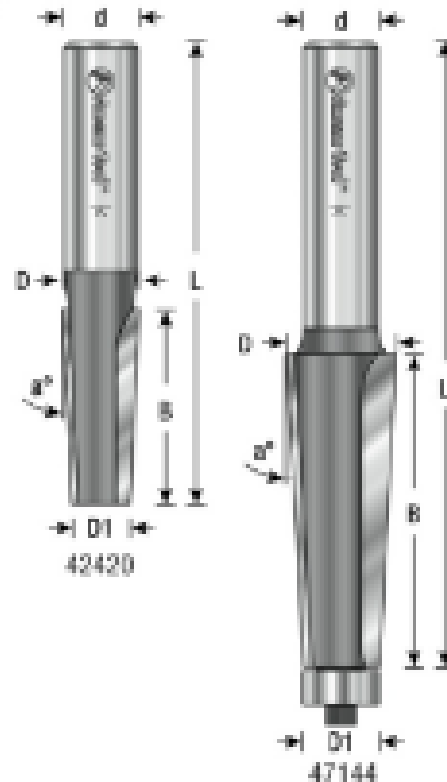

Item #	Diameter	Cut Height, Length, or Width	Diameter (D1)	Flute	Overall Length	Shank	Angle	Manufacturer	Price
42420	1/2 in	1 1/4 in	3/8 in	2	1 3/4 in	1/2 in	3 deg	Amana Tool	<b>\$41.10</b>
42422	19/32 in	1 1/4 in	3/8 in	2	3 5/32 in	1/2 in	5 deg	Amana Tool	<b>\$58.01</b>
42424	13/16 in	1 1/4 in	3/8 in	2	3 5/32 in	1/2 in	7 deg	Amana Tool	<b>\$58.01</b>
47144	3/4 in	2 1/8 in	1/2 in	2	4 5/8 in	1/2 in	3 deg	Amana Tool	<b>\$65.33</b>