

## Edge of Arlington Saw & Tool, Inc.

124 South Collins  
 Arlington, TX 76010  
 Phone: 817-461-7171 • Fax: 817-795-6651  
 Toll Free: 888-461-7171  
 Email: [info@eoasaw.com](mailto:info@eoasaw.com)  
 Website: [www.eoasaw.com](http://www.eoasaw.com)

### Application: Peripheral Milling & Face Milling

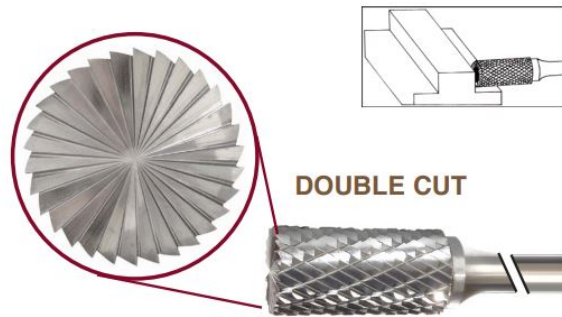

## Viking Drill & Tool SB Cylinder Shape With End Cut - Double Cut: Peripheral Milling & Face Milling

Thank you for shopping with us!

**Application:** Peripheral Milling & Face Milling

#### Double Cut

*The most popular burr for ferrous applications.*

*The flutes are ground in both the left and right hand directions, offering better operator control and rapid stock removal in harder materials.*

*The double cut geometry reduces the size of the chips and can be used at slower than normal speeds.*



#### Aluma Cut

*Designed for use on aluminum, non-ferrous metals, soft steel, reinforced plastics and other soft materials.*

*The burrs are designed with a high flute finish for easy chip flow and fast stock removal and excellent work piece finish.*



MATERIALS	Aluma Cut	Double Cut
Aluminum	✓	
Brass		✓
Bronze		✓
Copper		✓
Cast Iron		✓
Plastics	✓	
Steel (40-50 RC)		✓
Steel (55-60 RC)		✓
Steel (Carbon)		✓
Steel (Nickel Chrome)		✓
Stainless Steel		✓
Steel Weldments		✓
Titanium		✓
Zinc	✓	

### Recommended RPM

Diameter	Standard Materials	Stainless Steel	Diameter	Standard Materials	Stainless Steel
1/16	72500	97500	5/16	28000	28000
3/32	65500	89000	3/8	25000	25000
1/8	56000	76000	7/16	22000	22000
5/32	46000	70000	1/2	18800	18800
3/16	40000	65500	5/8	17000	17000
1/4	35000	61000	3/4	14900	14900
			1"	12600	12600

Item #	Manufacturer	Diameter	Cut Height, Length, or Width	Shank	Size	Type	Price
17409	Viking Drill & Tool	1/16 in Cut Dia	1/4 in Cut Length	1/8 in	SB-41	Cylinder Shape, With End Cut, Double Cut	<b>\$8.27</b>
17419	Viking Drill & Tool	3/32 in Cut Dia	7/16 in Cut Length	1/8 in	SB-42	Cylinder Shape, With End Cut, Double Cut	<b>\$8.27</b>
17429	Viking Drill & Tool	1/8 in Cut Dia	9/16 in Cut Length	1/8 in	SB-43	Cylinder Shape, With End Cut, Double Cut	<b>\$8.27</b>
17439	Viking Drill & Tool	1/8 in Cut Dia	1/2 in Cut Length	1/4 in	SB-11	Cylinder Shape, With End Cut, Double Cut	<b>\$18.14</b>
17449	Viking Drill & Tool	1/8 in Cut Dia	5/8 in Cut Length	1/4 in	SB-12	Cylinder Shape, With End Cut, Double Cut	<b>\$17.96</b>
17459	Viking Drill & Tool	5/32 in Cut Dia	5/8 in Cut Length	1/4 in	SB-13	Cylinder Shape, With End Cut, Double Cut	<b>\$17.96</b>
17469	Viking Drill & Tool	3/16 in Cut Dia	5/8 in Cut Length	1/4 in	SB-14	Cylinder Shape, With End Cut, Double Cut	<b>\$17.02</b>
17479	Viking Drill & Tool	1/4 in Cut Dia	3/16 in Cut Length	1/8 in	SB-51	Cylinder Shape, With End Cut, Double Cut	<b>\$14.56</b>
17489	Viking Drill & Tool	1/4 in Cut Dia	5/8 in Cut Length	1/4 in	SB-1	Cylinder Shape, With End Cut, Double Cut	<b>\$15.51</b>
17499	Viking Drill & Tool	1/4 in Cut Dia	1 in Cut Length	1/4 in	SB-1L	Cylinder Shape, With End Cut, Double Cut	<b>\$19.19</b>
17509	Viking Drill & Tool	5/16 in Cut Dia	3/4 in Cut Length	1/4 in	SB-2	Cylinder Shape, With End Cut, Double Cut	<b>\$20.23</b>
17519	Viking Drill & Tool	3/8 in Cut Dia	3/4 in Cut Length	1/4 in	SB-3	Cylinder Shape, With End Cut, Double Cut	<b>\$20.74</b>
17529	Viking Drill & Tool	3/8 in Cut Dia	1 in Cut Length	1/4 in	SB-3L	Cylinder Shape, With End Cut, Double Cut	<b>\$31.02</b>
17539	Viking Drill & Tool	3/8 in Cut Dia	1 1/2 in Cut Length	1/4 in	SB-3X	Cylinder Shape, With End Cut, Double Cut	<b>\$43.34</b>
17549	Viking Drill & Tool	7/16 in Cut Dia	1 in Cut Length	1/4 in	SB-4	Cylinder Shape, With End Cut, Double Cut	<b>\$30.37</b>
17559	Viking Drill & Tool	1/2 in Cut Dia	1 in Cut Length	1/4 in	SB-5	Cylinder Shape, With End Cut, Double Cut	<b>\$33.55</b>
17569	Viking Drill & Tool	5/8 in Cut Dia	1 in Cut Length	1/4 in	SB-6	Cylinder Shape, With End Cut, Double Cut	<b>\$51.46</b>
17579	Viking Drill & Tool	3/4 in Cut Dia	1/2 in Cut Length	1/4 in	SB-15	Cylinder Shape, With End Cut, Double Cut	<b>\$80.07</b>
17589	Viking Drill & Tool	3/4 in Cut Dia	3/4 in Cut Length	1/4 in	SB-16	Cylinder Shape, With End Cut, Double Cut	<b>\$74.16</b>
17599	Viking Drill & Tool	3/4 in Cut Dia	1 in Cut Length	1/4 in	SB-7	Cylinder Shape, With End Cut, Double Cut	<b>\$74.16</b>
17619	Viking Drill & Tool	7/8 in Cut Dia	1 in Cut Length	1/4 in	SB-8	Cylinder Shape, With End Cut, Double Cut	<b>\$106.05</b>
17629	Viking Drill & Tool	1 in Cut Dia	1 in Cut Length	1/4 in	SB-9	Cylinder Shape, With End Cut, Double Cut	<b>\$120.36</b>